



## Research Article

## Elderly People Health Care Monitoring System Using Internet of Things (IoT) For Exploratory Data Analysis

Rahul Sanmugam Gopi<sup>1,\*</sup>, R.Suganthi<sup>2</sup>, J. Jasmine Hephzipah<sup>3</sup>, G.Amirthayogam<sup>4</sup>, P.N.Sundararajan<sup>5</sup>, T.Pushparaj<sup>6</sup>

<sup>1</sup>Department of Electronics and Communication Engineering, Vel Tech Rangarajan Dr. Sagunthala R&D Institute of Science and Technology, Chennai 600062, Tamil Nadu, India.

<sup>2</sup>Department of Electronics and Communication Engineering, Panimalar Engineering College, Poonamallee, Chennai-600123, Tamil Nadu, India,

<sup>3</sup>Department of Electronics and Communication Engineering, R.M.K. Engineering College, Kavaraipettai, Tamil Nadu 601206, India ,

<sup>4</sup>Department of Information Technology, Hindustan Institute of Technology and Science, Chennai, Tamil Nadu 603103, India.

<sup>5</sup>Department of Electronics and Communication and Engineering, PSNA College of Engineering and Technology, Dindigul 624622. Tamil Nadu, India.

<sup>6</sup>Department of Information Technology, The American College, Madurai. Tamil Nadu, India.

## ARTICLE INFO

## Article History

Received 15 Mar 2024

Revised 01 Mar 2024

Accepted 13 May 2024

Published 02 Jun 2024

## Keywords

ESP 8266

Temperature Sensor

Pulse Rate (BPM)

GPS (Global positioning system)

Buzzer

Think Speak (IoT).

## ABSTRACT

The majority of senior persons are suffering a loss of physical condition their health is vital, the prevalence of illnesses has increased in the current age compared to previous generations, making health management in hospital sector. One of the concepts that can harness the advantages of the Internet of Things to better the older lifestyle is health monitoring for active and aided functioning. This approach aims to create a wireless communication system designed to remotely monitor patients. Each patient is wirelessly monitored based on Body temperature is measured via a temperature sensor, which gives an accuracy of around some certain value. The sensor carries a heart rate monitor with a pulse oximetry sensor. There are two light-emitting in it; one produces red light and the other infrared light. For tracking the amount of oxygen in the blood, two infrared LEDs are needed, but only one is needed to calculate the heart rate. The ESP 8266 (Node MCU) controller gathers the data and sends it to the specific application and Communication will be sent again to the consumers based on the data examination. The outcome results manage each patient's data separately and are used in hospitals, old age homes, and physically challenged people. Every sensor of data, such as temperature, heart rate, and abnormal heartbeat, will be managed in the database processed with GPS coordinates and data analyses using Think Speak Web Application is for informing about personal health data.



## 1. INTRODUCTION

Traditional healthcare systems have long relied on episodic and reactive medicine models. Patients visit healthcare providers only when they become ill or need medical treatment. Although it has been effective, this approach has left gaps in continuous patient monitoring, early disease detection and timely intervention. The IoT creates a paradigm shift in the healthcare sector and allows constant patient monitoring of their health status and adherence to prescription drugs. The Internet of Things means connecting every object with sensors to gather data and transmit it to the centralized systems. This concept has come to be known as the "IoT Based Patients Health Monitoring System" when it comes to healthcare. These systems consist of wearable devices, smart sensors, and mobile applications that work together to track vital signs, monitor chronic conditions, and provide personalized health information to patients.

Our IoT healthcare monitoring and medication alert system is designed to empower both patients and healthcare professionals. It is an interconnected network of devices and sensors that constantly gather and send critical health data such as heart rate, blood pressure, and temperature or oxygen level to a central platform. The platform uses ESP 8266

\*Corresponding author. Email: rahulgopi1993@yahoo.com

controllers to collect sensors' data, giving patients accurate and up-to-date information on their health. The Think Talk online application receives immediate time health data collected by sensors for the individual from the ESP 8266 controller, allowing healthcare professionals and the patient's family to check on the patient's condition from anywhere with the patient's current location through the Internet utilizing IoT.

One of this system's key benefits is its ability to notify the patient about drug interactions. In the healthcare industry, medication non-compliance poses a serious problem that can result in difficulties and hospital stays. Patients who use our IoT solution get automatic medication reminders and notifications, ensuring they never forget to take a dosage. Additionally, remote medication adherence monitoring is possible with the help of medical experts and cares who can act quickly if something goes wrong. In rising telemedicine and remote care, our IoT-based patient healthcare monitoring system and medication alerting system are intended to promote proactive healthcare management. In addition to improving patient well-being, avoiding readmission and problems in the hospital also lowers the financial burden on the healthcare system.

### 1.1 Objectives

1. To Continuous temperature monitoring is useful for tracking the evolution of fever and informing healthcare professionals about treatment options.
2. To management patient data using think Speak Web Application and maintain individual patient to take care and given medicine in manner.
3. To find the patient's location, a GPS device can be embedded into the emergency response system in emergency services.
4. To helpful to doctors, helping them patients and provide prompt treatment for those most at risk. They can help to control the spread of diseases, too.

## 2. LITERATURE REVIEW

In this work Internet of Things and Machine Learning to address health complaints. The system framework may be used to determine body specifications for the patient at once. The sensors read patient body characteristics and transmit them to the microcontroller, which transfers that information to the cloud, with the help of an Android application, a patient may look at this information [1].

To store continuous data, a methodology has been proposed that uses different machine learning algorithms together with cloud computing. These technologies have had a significant impact on healthcare in recent years. To detect hazards and provide the right diagnosis and treatment, physicians use medical data analysis tools and methods based on machine learning. Anything from tracking chronic diseases such as elderly patients or premature infants to victims of accidents is part of the scope of telemedicine. The current trial examines the ability of machine learning technology to monitor remote patients and provide them with information about their status via a remotely operated system [2].

The monitored information is provided to the medical; the system informs the medical about the aberrant parameter when it encounters anomalies. Minimizes the necessity for manual medical monitoring as a result. Data from sensors is sent to the cloud platform using our suggested system's MQTT clients. Communications protocol that performs well with low-bandwidth, high-latency, or unstable networks as well as resource-constrained devices. The outcome of the work provides delivery reliability and a certain degree of assurance, the design ideologies attempt to reduce the amount of network bandwidth and device resources required. [3].

Rural hospitals or small clinics with very few doctors per patient can be equipped with the self-Health Monitoring System. The attendants can measure these parameters and reduce the burden on the doctor. The outcome real-time online monitoring for the patient by any doctor or healthcare professional, data taken on this device shall be stored in a cloud environment and, therefore, analyzed using machine learning algorithms [4].

The primary outcome was inpatient; death, duration of stay in the hospital, ER visits, and outpatient visits were secondary outcomes. Standard, pooled hazard ratio, and proportion of means analyses were performed. Hospital admissions decreased by 9.6% due to the adoption of digital alert systems, according to an aggregated random effect enquiry. The mean difference in hospital LOS decreased by 1.043 days due to digital alerting. A 3% decrease in all causes of death due to the Digital Alerting Systems has been observed [5].

Developed an intelligent monitoring system for use in a hospital, in addition to collecting data on patients with BT, HR or other vital signs, it also monitors the hospital's environment, including CO<sub>2</sub>, CO<sub>2</sub> and humidity. In all cases, there is a 95 % agreement between monitoring and real data on the attainment rate of current healthcare systems [6].

Classifications have been used to organize nine different disease-related datasets. The four variables used for measuring the classification performance are AUC, accuracy, sensitivity and specificity. There were three phases in which this research was carried out: collecting, processing and executing data; defining the resulting visibility to physicians or end users with results stored on cloud servers. According to the study authors, RF classification is the best for various clinical diseases regarding accuracy, sensitivity, specificity and AUC [7]. The patients' average heart rates (HRs) were 72, 75, and 78 beats per minute. According to the measurements, the SpO2 concentrations were 94, 97, and 98%, respectively. The temperatures were measured, they were 94.78, 95.6, and 97.4 degrees Fahrenheit, respectively test taken [8].

The Internet of Things system will inform the physician or health care professional. The maximum relative error (% $\epsilon$ ) in heart rate measurement, patient body temperature and SPO2 were found to be 2.89%, 3.03%, and 1.05%, respectively, comparable to the commercial health monitoring system. The Internet of Things-based health monitoring system enables physicians to capture accurate data quickly and easily [9].

The personal health dashboard, where biomedical information obtained by sensors is readily available for the physician and a team of specialists to assess and analyze in real time, is an additional important challenge to be addressed when developing intelligent healthcare monitoring systems. In order to monitor and detect early signs of COVID-19. [10]- [11].

Life, a technology that uses light waves to find glucose in the human body using sensors, is used for this work. For patients with diabetes, this system has been developed. Life technology has been a major drawback to this model because light waves cannot penetrate obstacles [12].

A well-trained ML model for prognosis and diagnosis may be used to analyze stored patient data. Machine learning algorithms use this monitoring data to train a model, together with previous health records of patients. It could provide valuable insight into the patient's condition and help healthcare personnel make more informed decisions [13].

Some of the applications of block chain and artificial intelligence in the healthcare sector, such as early detection of outbreaks, supply chain management of drugs and other equipment and contract tracing, have been discussed. The result such as contract tracing, vaccination monitoring, and pandemic management and control [14].

In the Internet of Things, a classification system prioritizes sensitive information. LSTM deep neural networks are deployed in cloud computing to remotely classify and monitor patients' conditions. The core of cloud computing uses the LSTM (long short-term memory) deep neural network algorithm. The result accuracy is 97.13%, with an improvement of 10.41% on average over alternative methods, when a method simulation and comparison between obtained results was carried out [15].

In this method performance measures for the MIT-BIH Arrhythmia dataset to carry out a complete analysis of DL models from Long Term Memory LTPTM concerning the classification of heartbeats. For classification purposes, a variety of LSTM DL models are offered. The LSTM DL models demonstrate that they are well suited to classifying heartbeats [16] - [17]

A significant negative effect on how well earlier strategies have been recognized, a new and improved CAD system based on the convolutional neural network CNN has been developed, which can distinguish between normal brain function and Alzheimer's disease. An assessment of the proposed approach, as well as results, have shown that a proposed CAD system is 96 per cent accurate [18]

The main innovation of this work is the use of computer-aided diagnosis to identify abnormalities in breast ultrasound photos made by combining a wavelet neural network, WNN, with grey wolf optimization algorithms. The evaluated by calculating a Confusion Matrix and receiver operating characteristic ROCKAUC curve [19]-[20].

## 2.1 Problem Statement

1. Complex data or conditions that challenge healthcare management in real time situations arise, LSTM models need to be retrained or adjusted.
2. Sensors data may having scaling problems in large-scale IoT-based healthcare systems with a sizable population of patients and sensors.
3. The optimization problem's increased complexity and dimensionality may make it difficult for the algorithm to manage them.
4. Monitoring threshold value is complex to reflect evolving patient needs and dosage schedules in real-time wireless sensor network model updating and fine-tuning may sometimes be complicated.

### 3. PROPOSED METHODOLOGY

In the proposed method we have developed a health monitoring system for elderly people living alone to improve lifestyle, to improve health care, and to support long-term medical studies. The parameters of the sensors used in this model were given to Arduino UNO. The Arduino UNO has been used to continuously analyze the received inputs of temperature sensor, heartbeat sensor, which were then sent to the server. A specific data is gathered for different people living alone to improve their treatment, and ESP 8266 (Node MCU) interface with several sensors are used to detect the various sensor parameters of the patient in hospital and to take medicine time in manner and GPS system is used to determine the patient's present location. An LCD and buzzer are also attached to the controller, allowing patients to monitor their health condition in real time. In the event of an emergency, it would automatically notify the doctor and the patient's relatives by SMS. Physicians will take prompt action after getting emergency information about the patient and may be able to save the patient's life. A data message is sent to their concerned doctor through IOT with help of serial USB communication and proposed block diagram shown in figure 1.

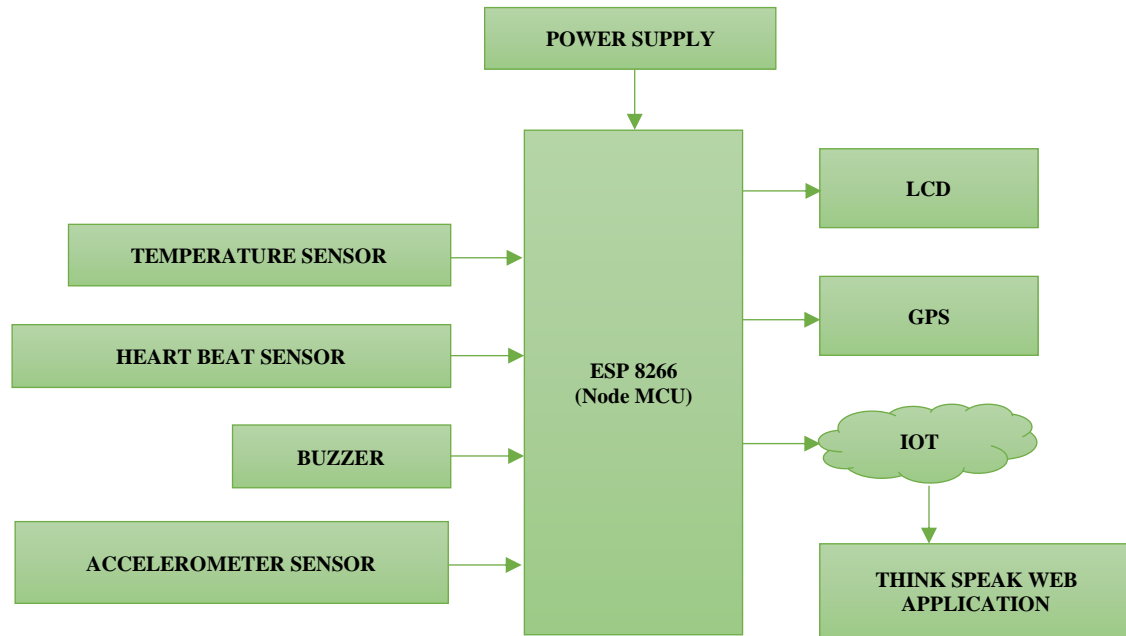

Fig. 1. Block diagram of Patient Health Monitoring using Think Speak Web Application

Each data for monitoring COVID-19 symptoms. The Pulse Rate (BPM) sensor monitors the patient's blood oxygen saturation levels (SpO<sub>2</sub>) and pulse rate. These parameters are essential for assessing the patient's respiratory health. An LCD provides real-time feedback to the patient, displaying their vital signs and status, it can also be used for local monitoring when healthcare providers are present.

The GPS module tracks the patient's location, providing valuable information for contact tracing and ensuring that patients adhere to quarantine or isolation protocols. The sensors and detectors detect the signals in analogue form, which needs to be further converted into digital form. The inbuilt analog-to-digital conversion is performed through the microcontroller to get data in proper digital format. The data are sent to ESP 8266, which is used as a microcontroller. Thing Speak is a cloud-based IoT platform for data storage, visualization, and remote access. It allows healthcare providers and caregivers to monitor patient data securely from any location with internet access. The buzzer is utilized to alert the patient about the pill.

#### 3.1 ESP 8266 Controller (Node MCU)

The Node MCU is a comprehensive open-source software and hardware development platform centered on the ESP8266 System-on-a-Chip (SOC). This is a flexible and cost-efficient solution to create Internet of Things applications. The ESP8266, at its core, consists of an intricately connected chip combining an MCU unit with built-in Wi-Fi capabilities and the ability to develop interconnected device applications, which makes it suitable for developing integrated device applications. Node MCU uses ESP8266's inherent capabilities to provide a user-friendly and convenient development environment for programming and interacting with the chip. A robust 32-bit ten silica MCU resides in the ESP8266 SOC,

providing the computational capacity to perform applications and manage multiple tasks. Moreover, the system provides ample onboard memory for efficient data storage and processing.

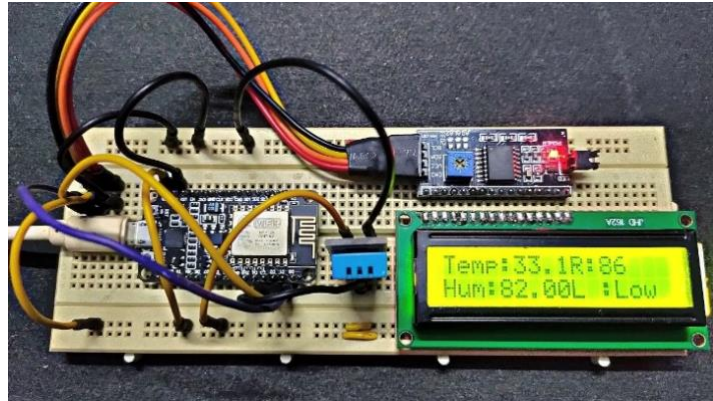

Fig. 2. ESP 8266 (Node MCU) module

Node MCU is compatible with Arduino IDE and allows developers to use the vast Arduino ecosystem, filled with a wide range of libraries and practical examples, as a supportive community. This integration makes developing projects faster and easier on the Node MCU Board. The Node MCU continues the simplicity and ease of use related to the Arduino platform while taking advantage of its unique features, such as Wi-Fi capability, GPIO pins and a host of additional components. This synergy facilitates the rapid development and deployment of IoT projects for developers, all within an easy-to-use Arduino programming environment. The ESP 8266 controller is shown in Figure 2. It collects sensor data and broadcasts the patient's health condition to the Thing Speak IoT web application, allowing medical personnel to easily monitor the patient and act fast to perform rescue procedures as needed.

### 3.2 Temperature Sensor

A continuous monitoring of the patient's body temperature can be carried out using a DHT11 sensor. Early signs of disease, e.g. a fever that may indicate infection or sickness, can be an increase in the body's temperature. This data can be communicated immediately to healthcare professionals, allowing prompt intervention. Remote monitoring via Internet of Things devices can be performed on patients with chronic illnesses or who recover after surgery. The temperature sensor can be integrated with a clothing device or an electronic home monitoring system to monitor temperature fluctuations and send alerts to healthcare staff or caregivers if abnormal readings are found.



Fig. 3. Temperature sensor output with LCD display output

The temperature sensor measures the patient's body temperature, and the ESP 8266 controller collects the sensor data. Whenever the temperature sensor surpasses a predefined threshold level, the controller sends alerts to the patient and healthcare professionals through IoT notifications, a functionality programmed in Python.

### 3.3 Heart Beat Sensor

The Heart Beat Sensor is an analyzer module that measures your blood's heart rate and oxygen saturation. The Heart Beat Sensor uses the principles of photo to measure heart rate. It emits infrared and red light through its skin, measuring how much hemoglobin the blood vessels absorb. For calculating the heart rate, these variations in light absorption are used.

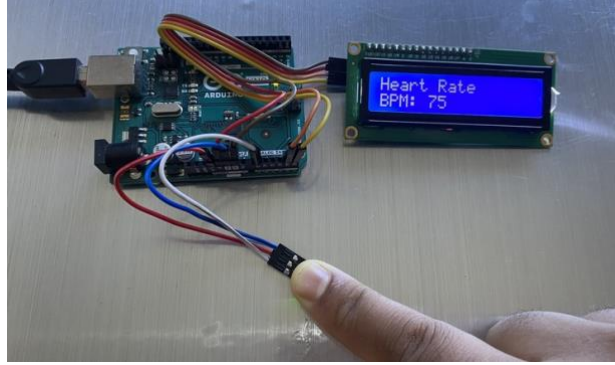

Fig. 4. Heart Beat Sensor module

Heart beat measures the percentage of oxygenated hemoglobin in your blood. The Heart Beat sensor uses the same PPG technique for measuring the Heart Beat. The oxygen saturation level shall be determined by comparing red and infrared light absorption. The sensor Heart Beat module typically comprises infrared LEDs, red lights, photo-detecting circuits and signal-conditioning circuitry. It is intended for use in some applications and to be easy to integrate.

In Figure 4, the Pulse Rate (BPM) is depicted, which gauges the patient's heart rate. The ESP 8266 Controller is responsible for gathering the sensor data. When the data surpasses or falls below the predetermined threshold, the controller transmits this information to the Thing Speak web application. This facilitates healthcare professionals in monitoring the patient and responding appropriately. The controller's threshold settings are programmed using the Python language. The alert notification is through the Think Speak web application and a buzzer, which makes an alert for the long term until the patient gets rescued.

### 3.4 GPS

The widely utilized and reasonably priced NEO-6M GPS module is a receiver module. The firm that makes it is u-box, a Swiss business renowned for its superior GPS and location technologies. Numerous electronic projects involving drones, robots, navigational systems, and location-based applications frequently include the NEO-6M module. The NEO-6M module shall be capable of receiving GPS satellite signals and calculating a device's location, velocity or time information. This module communicates to microcontrollers or other devices via a serial UART Universal Asynchronous receiver Transmitter interface.

When receiving a satellite signal, the module usually requires an external GPS antenna. The SMA or U.FL connectors connect the antenna to the module. When receiving a satellite signal, the module usually requires an external GPS antenna. The SMA or U.FL connectors connect the antenna to the module. The Neo6M modules are usually operated at a voltage of 3.3v and consume very little power, allowing them to be used in battery charger applications.

Figure 5 illustrates the NEO-6M GPS Module, which is crucial in efficiently pinpointing the patient's location via satellite connectivity. It also triggers alerts through the Think Speak IoT web application, allowing healthcare professionals to remotely monitor the patient's status. This GPS module simultaneously sends the location of the patient over IoT.

### 3.5 LCD

The conventional character set supported by a 16x2 LCD normally consists of numerals (0–9), capital letters (A–Z), a few special characters, and user-definable custom characters. Depending on the type and application, most 16x2 LCD screens interact with microcontrollers or other control equipment utilizing parallel or serial communication protocols. Although certain versions may differ, these displays usually function at low voltage levels, frequently about 5 volts. To guarantee optimal operation, the right voltage and current must be supplied.



Fig. 6. 16\*2 LCD Display

Figure 6 illustrates the circuit diagram for the LCD, which presents the patient's health data collected through various sensors and facilitates the scheduled administration of medication to the patient through controller programming accomplished using the Python language.

### 3.6 Buzzer

The type of audio signal device can be electronic or mechanical, for instance, beepers and buzzers. Conversion of the signal from audio to sounds is its primary function. It may be used for Timers, alarm devices, printers, alarms, computers, etc. and normally operates using DC voltage. Depending on the design, it may create different sounds, such as alarms, music, bells and sirens. The piezoelectric type causes the metal plate to vibrate and produce sound using the piezoelectric effect and pulse current of the piezoelectric ceramic. Resonance boxes, multiple resonators, piezoelectric plates, housing, impedance matches, and other components create this buzzer. Some buzzers have LEDs included in their design as well.

This multi-resonator mostly consists of transistors and integrated circuits. This resonator will oscillate and produce an audio signal at 1.5 to 2.0 kHz as soon as the supply is applied. The impedance matcher will force the piezoelectric plate to make a sound. The buzzer's pin configuration is seen below. It has two pins: a positive pin and a negative pin. The '+' sign or a longer terminal indicates this positive terminal. While the positive terminal is shown by the '+' symbol or long terminal and is connected to the GND terminal, the negative terminal is represented by the '-' symbol or short terminal.

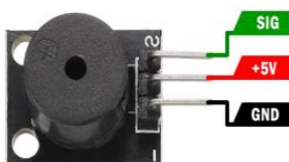

Fig. 7. Pin Configuration of Buzzer

In Figure 7, observe the buzzer pin setup. In this approach, the buzzer is employed to notify the patient of medication schedules. An extended buzzer tone is an emergency alert, triggering when the patient's temperature or heart rate surpasses the threshold level preconfigured in the controller through Python programming.

## 4. RESULT AND DETECTION

The Smart Health management system is particularly useful for both patients and doctors. Patients may monitor their health condition at any time from the comfort of their own homes, and they only have to attend hospitals when truly required. Because it is a prototype model, our system displays practically real-time numbers for several health demonstrates how they may be applied in real-life situations, Physicians may also use the record of the patient's physical condition.

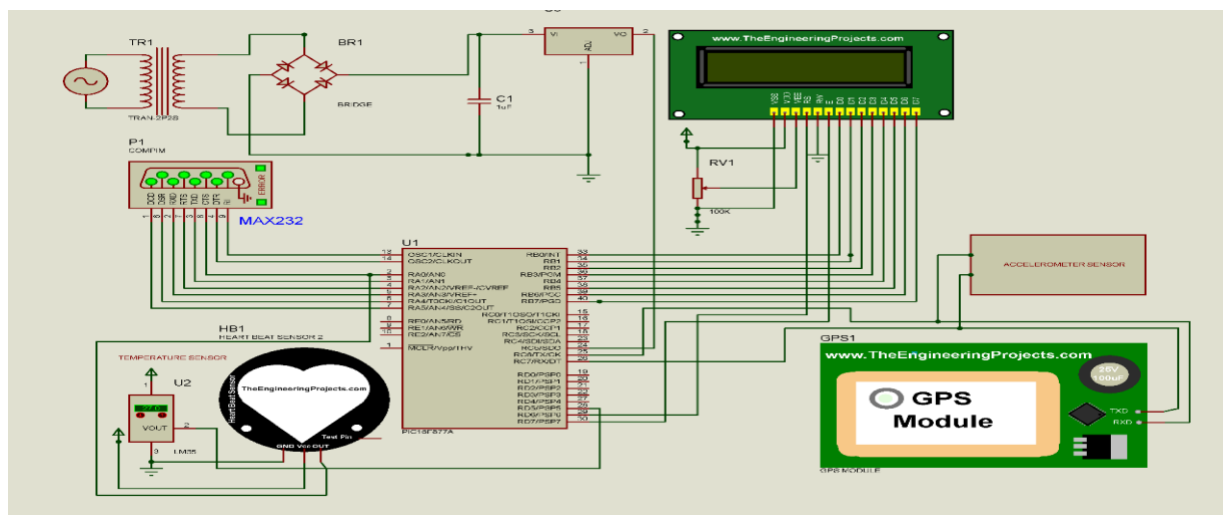

Fig. 8. Simulated outcome from the Health care monitoring

The health monitoring system gives a solution to this challenge. It helps medical personnel to monitor some important health indices of patients and avoided concerns. This is accomplished by monitoring body temperature, identifying falls, and food consumption. The properly captured data can be employed for future reference by doctors when operating on the individual in need.

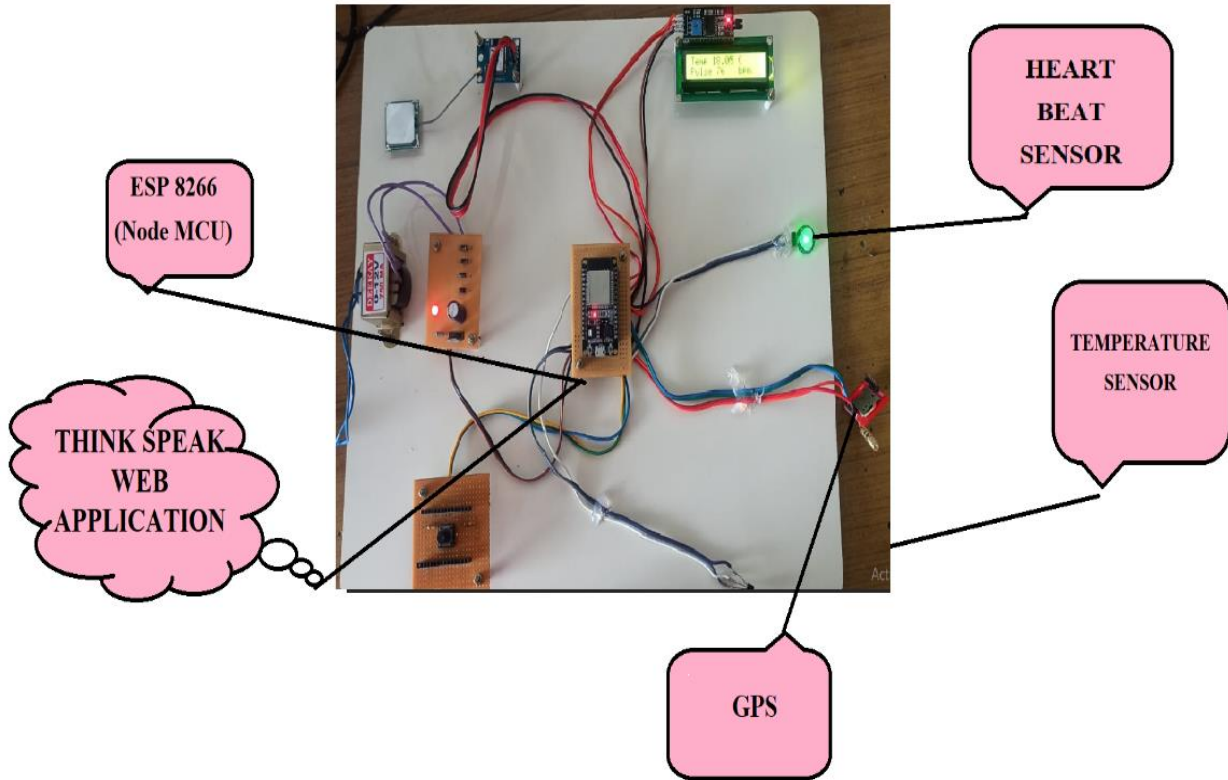

Fig. 9. Hardware output of health care monitoring

The alert and messaging system will promptly notify the physicians and family if any problem happens, allowing them to concentrate on other tasks and eliminating the continual need for participation. Patient health monitoring systems rely largely on the Internet of Things to monitor the health of their patients. Considering its early stages, the Internet of Things having an opportunity to have significant effects on the human medical field. Figure 8 shows the Proteus Unit contains a number of functions that allow users to communicate with each sensor and wireless communication module.

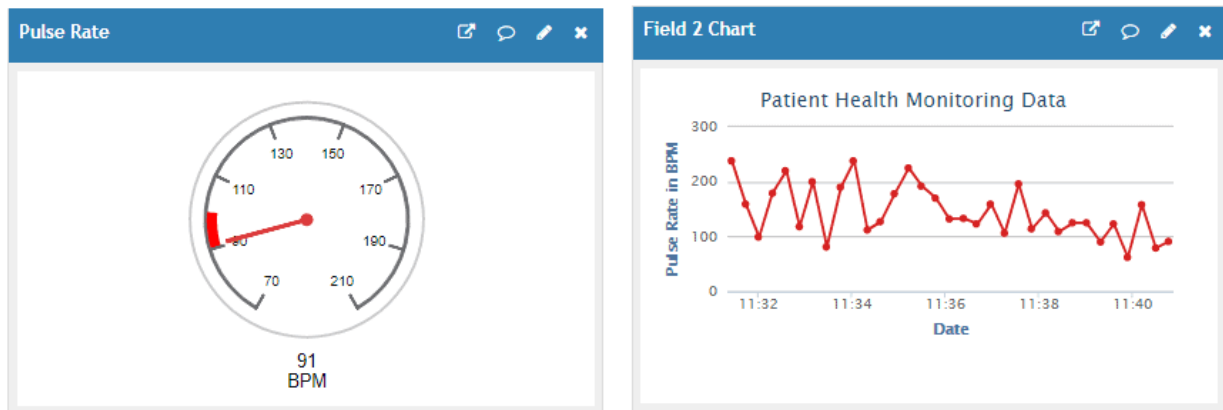

Fig. 10. IOT Based Think Speak Web Application

Thing speak provides us with real-time visual representations of pulse rate data that our specific devices send to the data are shown in figure 10 and also findings that will be presented on the LCD are also visible in Thing speak.

When the application is performed, outcomes will be shown in a virtual terminal for all variables and simulated as part of the verification process, and the results are sensors concluded used in health care monitoring. Figure 9 hardware shows the data of each sensor and display in LCD, real-time availability of patient conditions, intelligent combining of data, smart maintaining data via online storage, and so on. IoT, along with digital devices, reduces difficulty and problems in the medical sector.



TABLE I. PATIENT DATA MANAGEMENT FOR HEALTH STATUS

TIME	Patient Data 1		Patient Data 2	
	Temperature in .C	Heart Rate (Bpm)	Temperature in .C	Heart Rate (Bpm)
9.15 AM	36.59	71.30	33.41	91.40
11.10 AM	37.39	70.25	32.52	90.65
2.30 PM	38.23	75.64	31.45	105.54
4.30 PM	32.47	77.20	30.34	95.10
8.30 PM	31.31	75.14	31.43	88.13

Table 1 Shows the data management of temperature and heartbeat monitoring device when they visit each home for a routine check-up. The system is made up of a wireless application and a portable measurement device and temperature and heart rate may be measured using the portable measurement tool.

## 5. CONCLUSION

An IoT-based health care management system that collects physiological information applying temperature, heart rate. The concluded analyses the human body's time management in order to and the detecting process in hospital or old age homes uses a certain level of threshold to identify variations from normal patterns. In an emergency situation, such as irregular heartbeat evaluations, high temperature an alarm is sent to the designated provider and required action is then performed based on the severity of the warning. Thing talk gives us with real-time visual representations of heartbeat data that our gadgets send to the data to concern person. In addition, all of the results that will be shown on the LCD also seen in Thing speak based on calculation shown in table 1. The experimental remote health management platform for every sick person, it will be built using easily accessible sensors remotely.

### 5.1 Future Scope

In future monitoring and evaluating vital indicators in real-time to identify or anticipate potentially fatal situations; Ensuring that they comply with to their medical treatment and taking their medication on schedule. Using neural network outcomes can also be calculated if a patient's health parameters change in a way that is comparable with the prior patient in the records.

### Conflicts Of Interest

The authors don't have any conflict of interest in regards of this research.

### Funding

The author's paper explicitly states that the research was self-funded and no support was received from any institution or sponsor

### Acknowledgements

Authors acknowledge the facilities provided by Publishing this Research article by "Centre for Networking and Cyber Défense" (CNCD) - Centre for Excellence, Department of Information Technology, Hindustan Institute of Technology and Science, Kelambakkam, Tamil Nadu -603103, India

### References

- [1] A. Poongodi, M. Bourouis, S. Band, A. Mosavi, S. Agrawal, et al., "Meta-Heuristic Algorithm-Tuned Neural Network For Breast Cancer Diagnosis Using Ultrasound Images," *Front. Oncol.*, vol. 12, 2022.
- [2] N. Al Bassam et al., "IoT Based Wearable Device to Monitor the Signs of Quarantined Remote Patients of COVID-19," *Inform. Med. Unlocked*, 2021.
- [3] M. Amdi, S. Bourouis, R. K. Rastislav, F. Mohmed, "Evaluation Of Neuro Image For The Diagnosis Of Alzheimer's Disease Using Deep Learning Neural Network," *Front. Public Health*, vol. 35, 2022.
- [4] A. Bahmani et al., "A Scalable Secure and Interoperable Platform for Deep Data-Driven Health Management," *Nat. Commun.*, 2021.
- [5] V. Bhardwaj, R. Joshi, A. M. Gaur, "IoT-Based Smart Health Monitoring System For COVID-19," *Sn Comput. Sci.*, 2022.
- [6] P. H. R. Biotene, A. T. De Azevedo, & P. S. De Arruda Ignácio, "Blockchain As An Enabling Technology In The COVID-19 Pandemic: A Systematic Review," *Health Technol.*, vol. 11, pp. 1369–1382, 2021.

- [7] F. Dahan, R. Alroobaea, W. Y. Alghamdi, K. M. Mustafa, F. Hajje, D. M. Alsekait, R. Raahemifar, "A Smart Home Based Architecture For E-Healthcare Patient Monitoring System Using Artificial Intelligence Algorithms," *Front. Physiol.*, 2023.
- [8] M. Dhinakaran, P. Khongdet, J. Alanya-Beltran, K. Srivastava, D. Vijendra Babu, S. Kumar Singh, "A System Of Remote Patients' Monitoring And Alerting Using The Machine Learning Technique," *J. Food Qual.*, 2022.
- [9] B. Ehera, R. Mehta, P. P. Fulzele, R. Sinha, "Regular Self-Health Monitoring and Medicine Reminder System with Emergency Alert Messaging Using IoT," *Internet of Things and Its Applications*, vol. 825, 2022.
- [10] S. Hiriyannaiah, G. M. Siddesh, M. H. M. Kiran, K. G. Srinivasa, "A Comparative Study and Analysis of LSTM Deep Neural Networks for Heartbeats Classification," *Heal Technol.*, vol. 11, pp. 663–71, 2021.
- [11] S. Iranpak, A. Shahbahrami, & H. Shakeri, "Remote Patient Monitoring And Classifying Using The Internet Of Things Platform Combined With Cloud Computing," *J. Big Data*, vol. 8, 2021.
- [12] M. M. Islam, A. Rahaman, M. R. Islam, "Development of Smart Healthcare Monitoring System In IoT Environment," *Sn Comput. Sci.*, 2020.
- [13] A. Kishor, C. Chakraborty, "Artificial Intelligence and Internet Of Things Based Healthcare 4.0 Monitoring System," *Wirel. Pers. Commun.*, pp. 1–17, 2022.
- [14] M. Poongodi, M. Malviya, M. Hamdi, H. T. Rauf, S. Kadry, O. Thinnukool, "The Recent Technologies to Curb the Second-Wave Of COVID-19 Pandemic," 2021.
- [15] F. M. Qbal, K. Lam, M. Joshi, et al., "Clinical Outcomes Of Digital Sensor Alerting Systems In Remote Monitoring: A Systematic Review And Meta-Analysis," *npj Digit. Med.*, vol. 4, 2021.
- [16] A. Tirkey, A. Jesudoss, "A Non-Invasive Health Monitoring System for Diabetic Patients," in *Proc. ICCSP*, pp. 1065-1067, 2020.
- [17] A. Tiwari, N. Parate, M. Khamari, A. Jaiswal, P. Joshi, P. Jadhav, "IoT Based Health Care Monitoring And Facilitation," in *Proc. ICETET-SIP-22*, pp. 1–6, 2022.
- [18] N. K. Visvesvaran, I. J. J. B. Kumar, P. Kaviya, and S. Kaviya, "Advanced Patient Monitoring and Alert System with Auto Medicine Suggestion Using Machine Learning," *Int. Conf. Electron. Sustain. Commun. Syst. (ICESC)*, pp. 829-833, 2022.
- [19] Yedavallyshivani Ravulapati, D. Aruvaneelima, and V. R. Rao, "Patient Health Monitoring with Doctor Alert Reporting Over IoT," *J. Interdiscip. Cycle Res.*, vol. 12, pp.1380-1391, 2020.
- [20] B. Zaabar, O. Cheikhrouhou, F. Jamil, M. Ammi, and M. Abid, "Healthblock: A Secure Blockchain-Based Healthcare Data Management System," *Comput. Networks*, 2021.